

PLAN VIEW DRAWING	
PRODUCT NAME: ActiveFit Shoulder Press Machine	
PRODUCT NUMBER: FIT-000050	REVISED JAN. 2018
ALL DIMENSIONS ARE IN INCHES	SCALE 1 : 16
www.activefit.ca 800-463-2361	

Parts List			
Item	Product Number	Product Name	QTY
1	FAS-000013	5/8" ASTM F436 Structural Flat Washer	12
2	FAS-000015	5/8"-11 18-8 SS Hex Nut	6
3	FAS-000014	5/8" x 5" Trubolt® 316 S/S Wedge Anchor	6

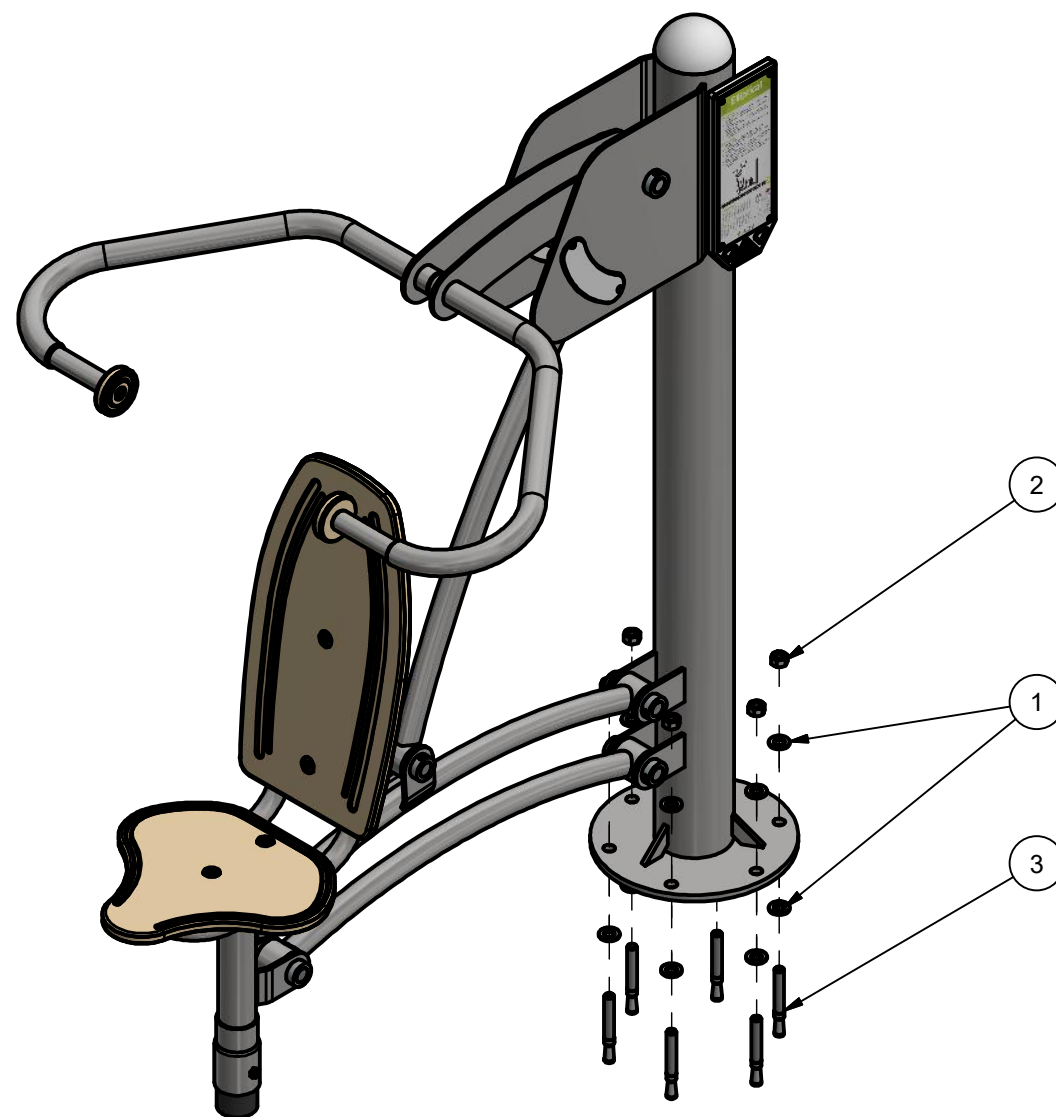

NOTE:
APPLY LOCKTITE TO BOLTS WHEN ASSEMBLING



INSTALLATION DRAWING	
PRODUCT NAME: ActiveFit Shoulder Press Machine	
PRODUCT NUMBER: FIT-000050	REVISED JAN. 2018
ALL DIMENSIONS ARE IN INCHES	SCALE 1 : 12
www.activefit.ca 800-463-2361	

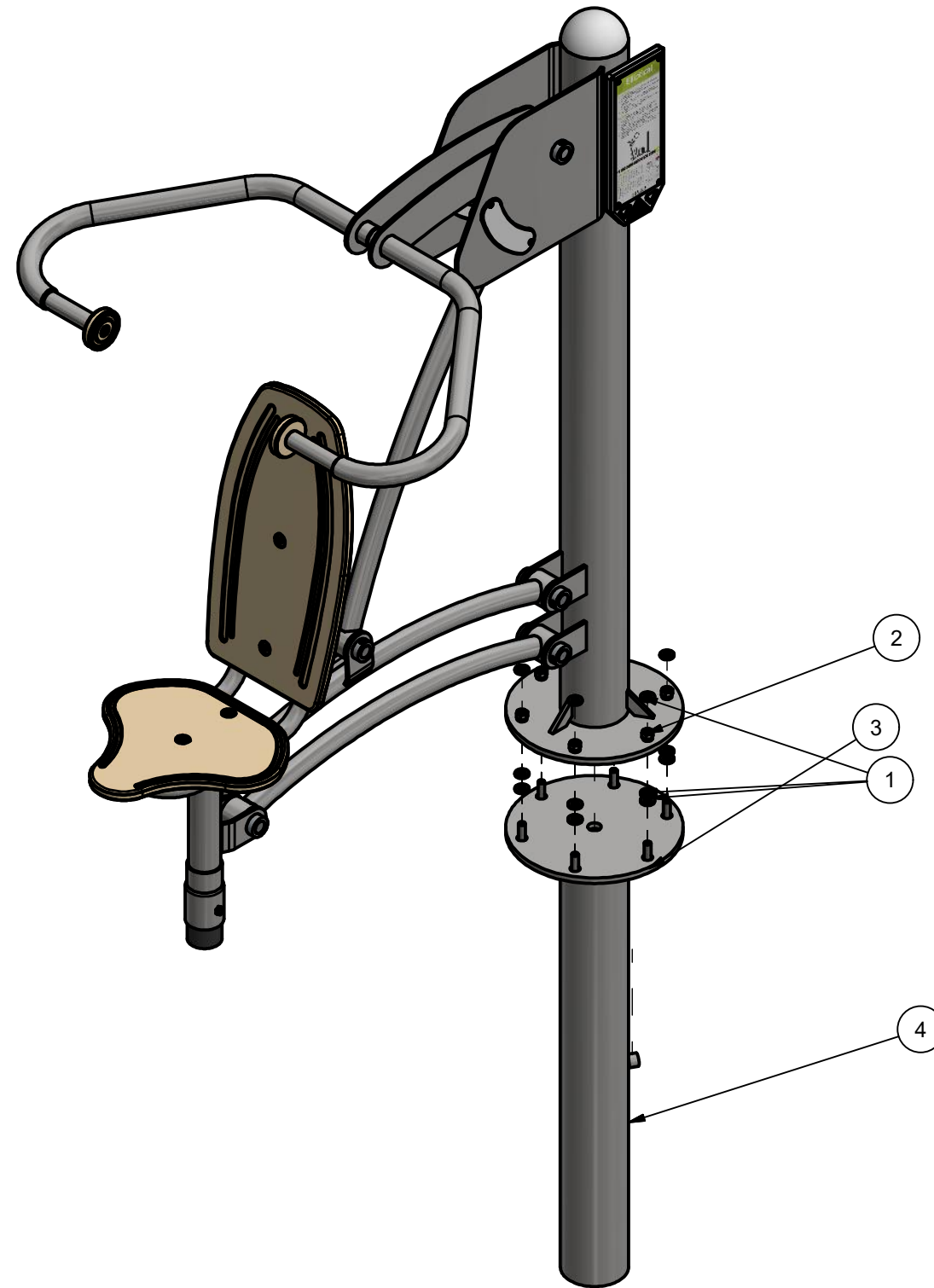

Parts List			
Item	Product Number	Product Name	QTY
1	FAS-000035	1/2" Galvanized Steel Structural Flat Washer	18
2	FAS-000034	1/2"-13 SS Hex Nut	6
3	FAS-000033	1/2" x 13 x 2" SS Button Socket Cap Screw	6
4	FDN-000002	Concrete Post Extension (13" dia Plate w/ 5" Post)(w/ Gussets)	1

NOTE:
APPLY LOCKTITE TO BOLTS WHEN ASSEMBLING



INSTALLATION DRAWING	
PRODUCT NAME: ActiveFit Shoulder Press Machine	
PRODUCT NUMBER: FIT-000050	REVISED JAN. 2018
ALL DIMENSIONS ARE IN INCHES	SCALE 1 : 12
www.activefit.ca 800-463-2361	

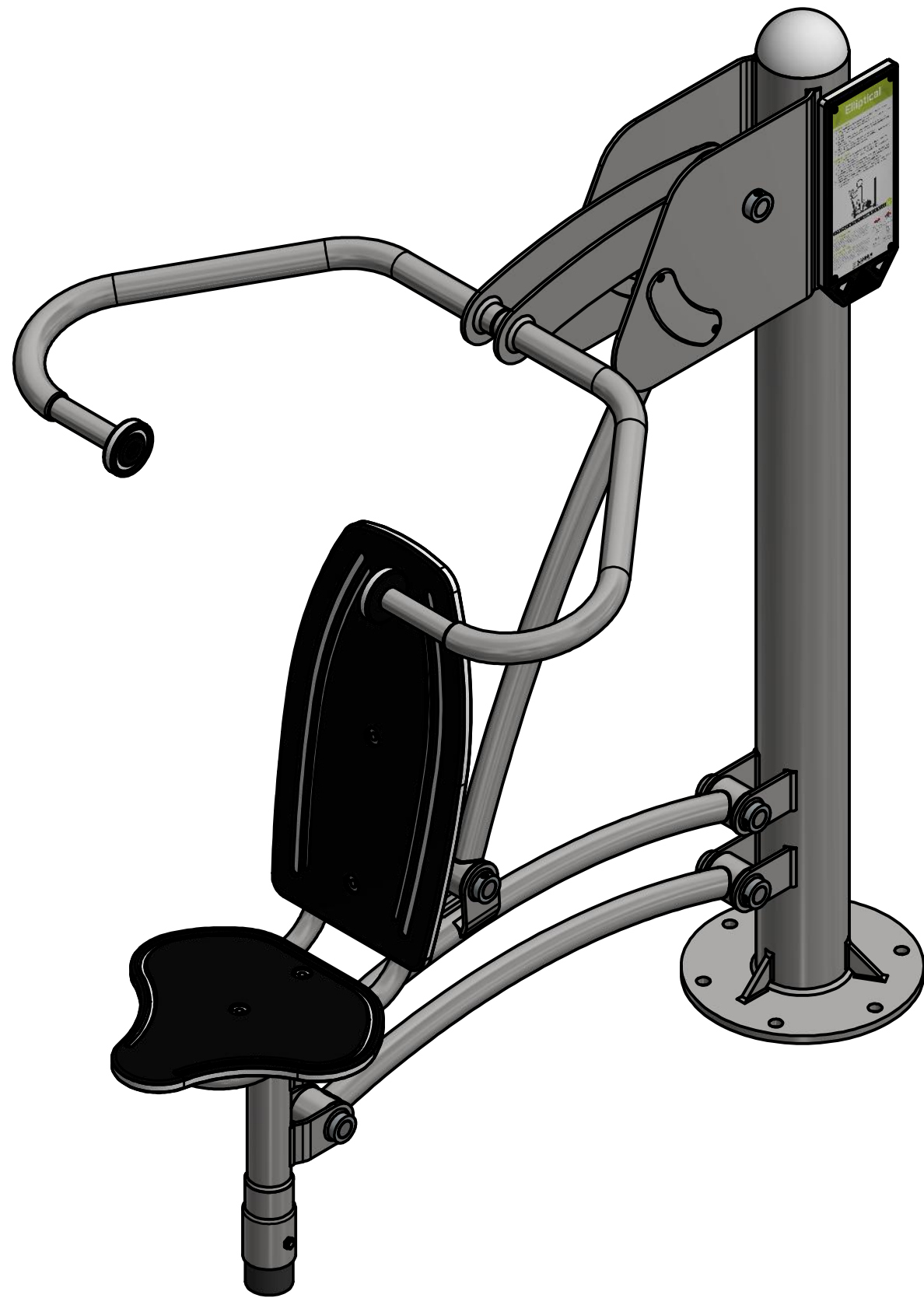

ASSEMBLY DRAWING	
PRODUCT NAME: ActiveFit Shoulder Press Machine	
PRODUCT NUMBER: FIT-000050	REVISED JAN. 2018
ALL DIMENSIONS ARE IN INCHES	SCALE 1 : 8
www.activefit.ca 800-463-2361	